

MOTIFS & TEMPLATES

**PRINT
OUT
& KEEP**

Use these guides to get started today

FIND THE TEMPLATE YOU REQUIRE ON THE CONTENTS LIST BELOW AND JUST PRINT OUT THE PAGE OR PAGES YOU NEED FROM YOUR PRINT MENU

In your print menu, under Size options, be sure to select to print 'Actual Size', instead of 'Fit to Page'

Page 2-12

Title: Draped top
Designer: Amanda Walker
Magazine page: 20

Page 13-17

Title: Fur stole
Designer: Amanda Walker
Magazine page: 40

Page 18

Title: Susie's stitch school
Designer: Susie Johns
Magazine page: 44

Page 19

Title: Reindeer runner
Designer: Kelly Fletcher
Magazine page: 68

Page 20-26

Title: Christmas stockings
Designer: Carolyn Letten
Magazine page: 70

Page 27-28

Title: Snowflake fairy doll
Designer: Jane Kharade
Magazine page: 89

Page 29-31

Title: Patchwork deer
Designer: Cheryl Owen
Magazine page: 92

Page 32-36

Title: Debbie Shore shows you how
Designer: Debbie Shore
Magazine page: 98

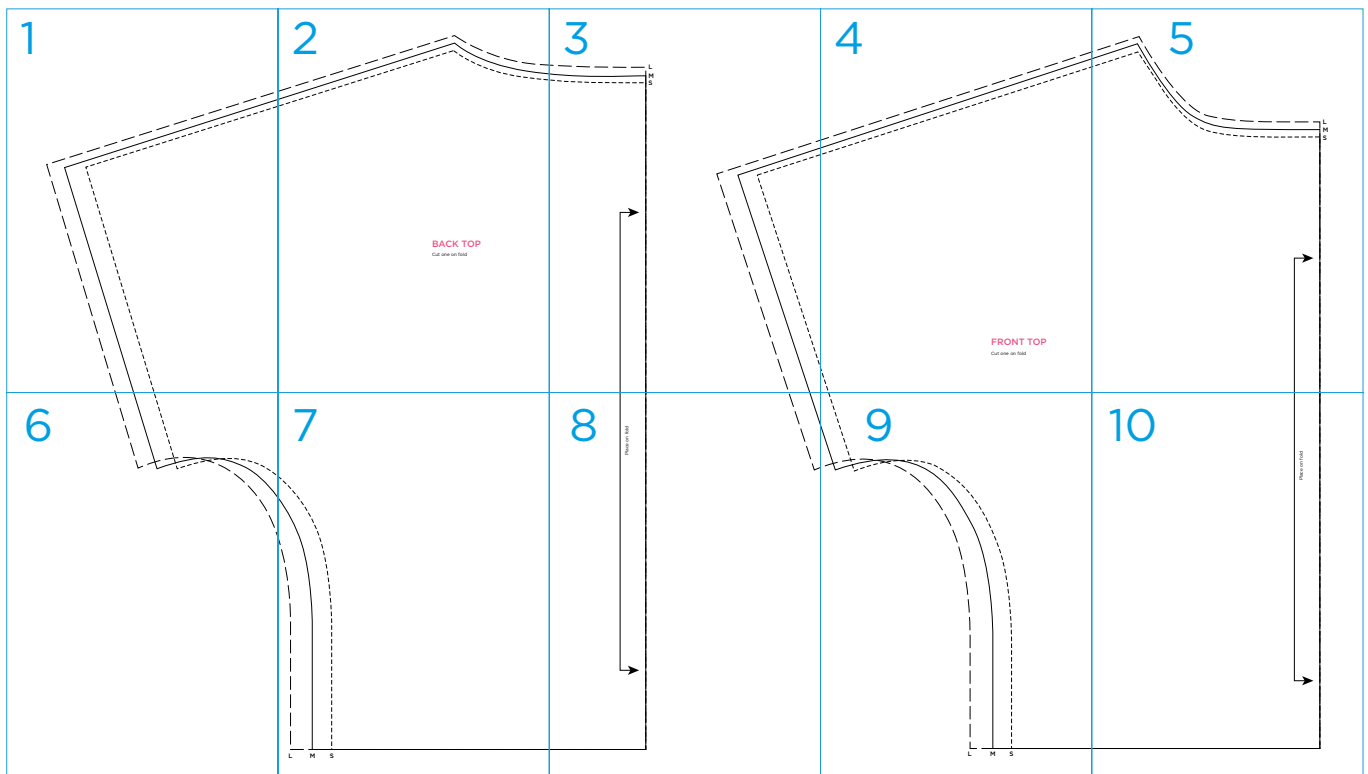

1

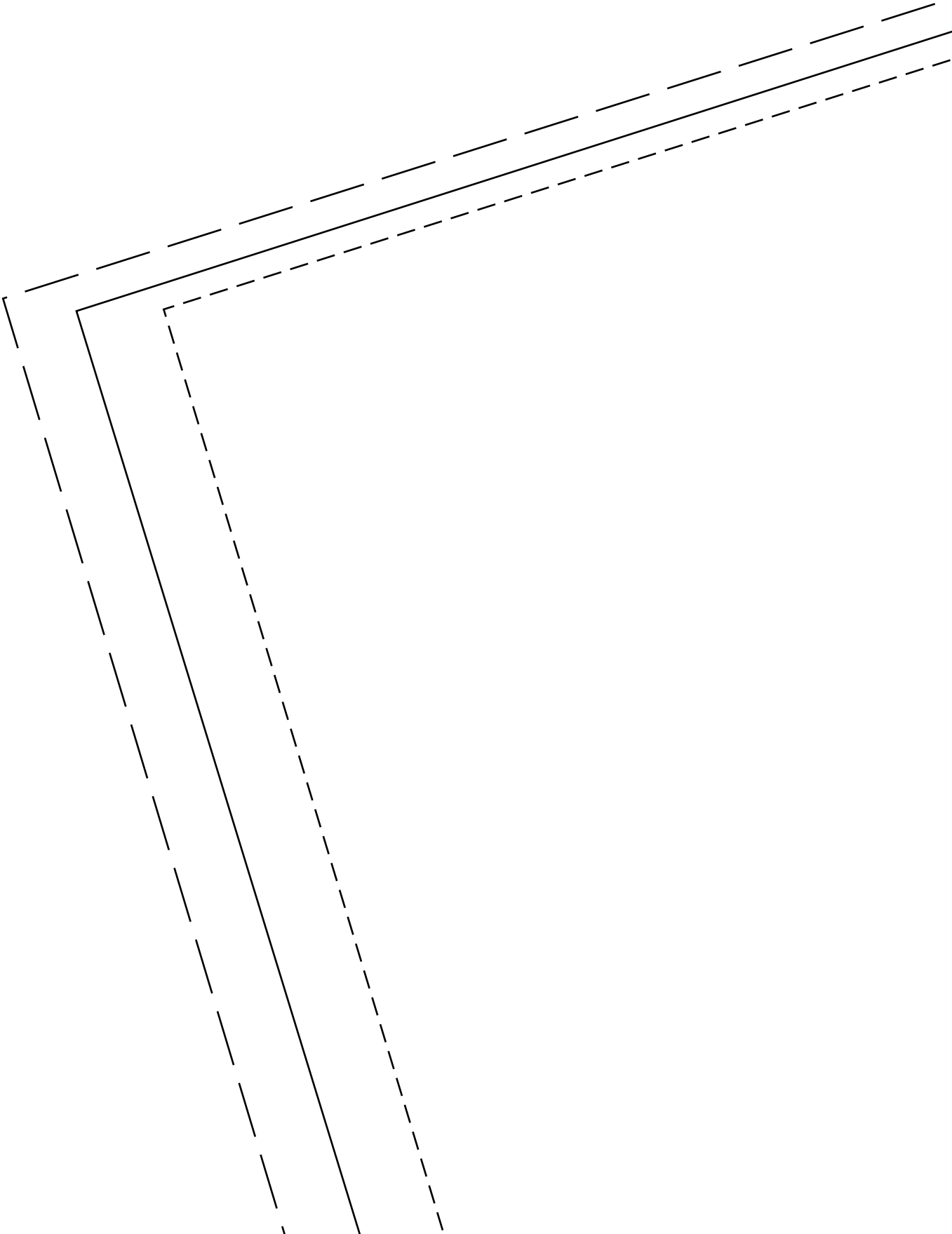

2

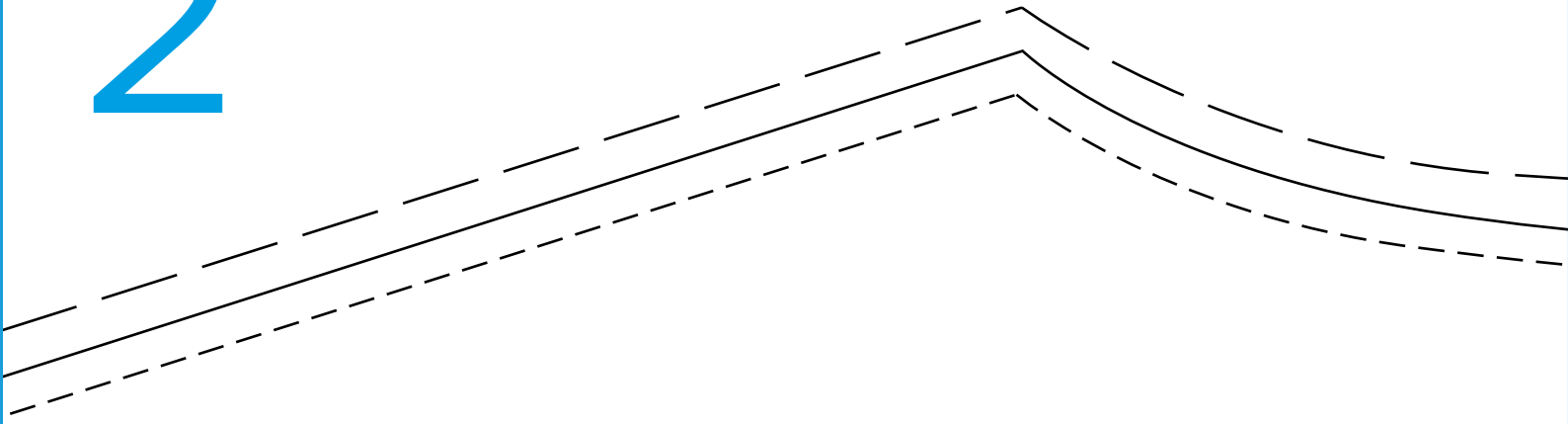

BACK TOP

Cut one on fold

3

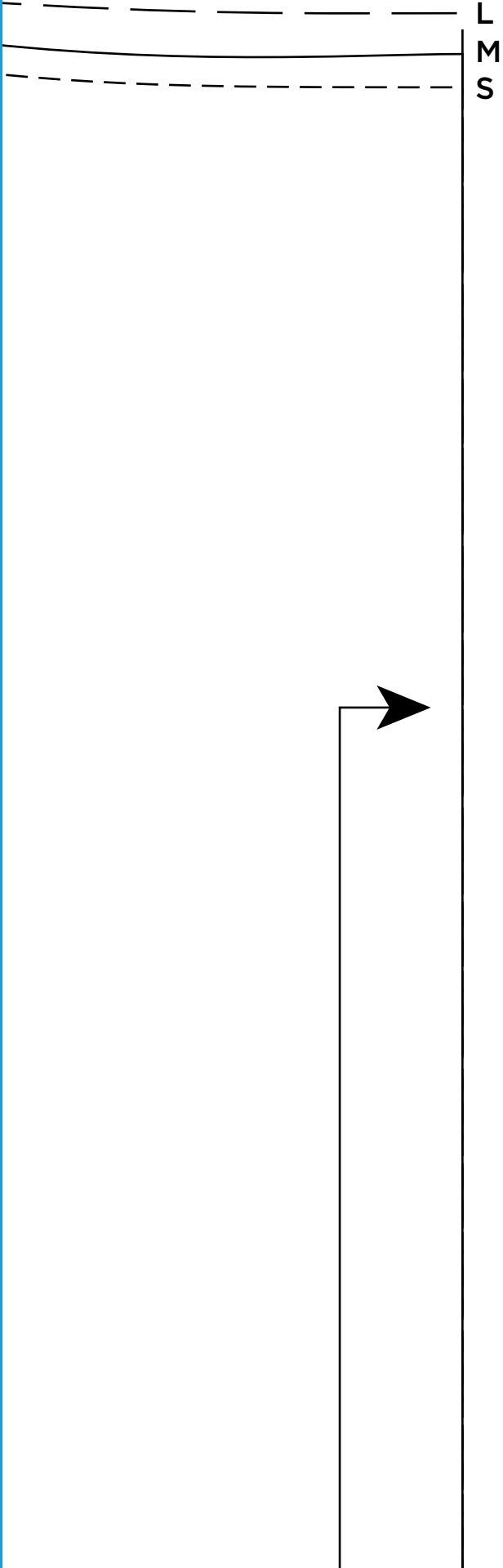

L
M
S

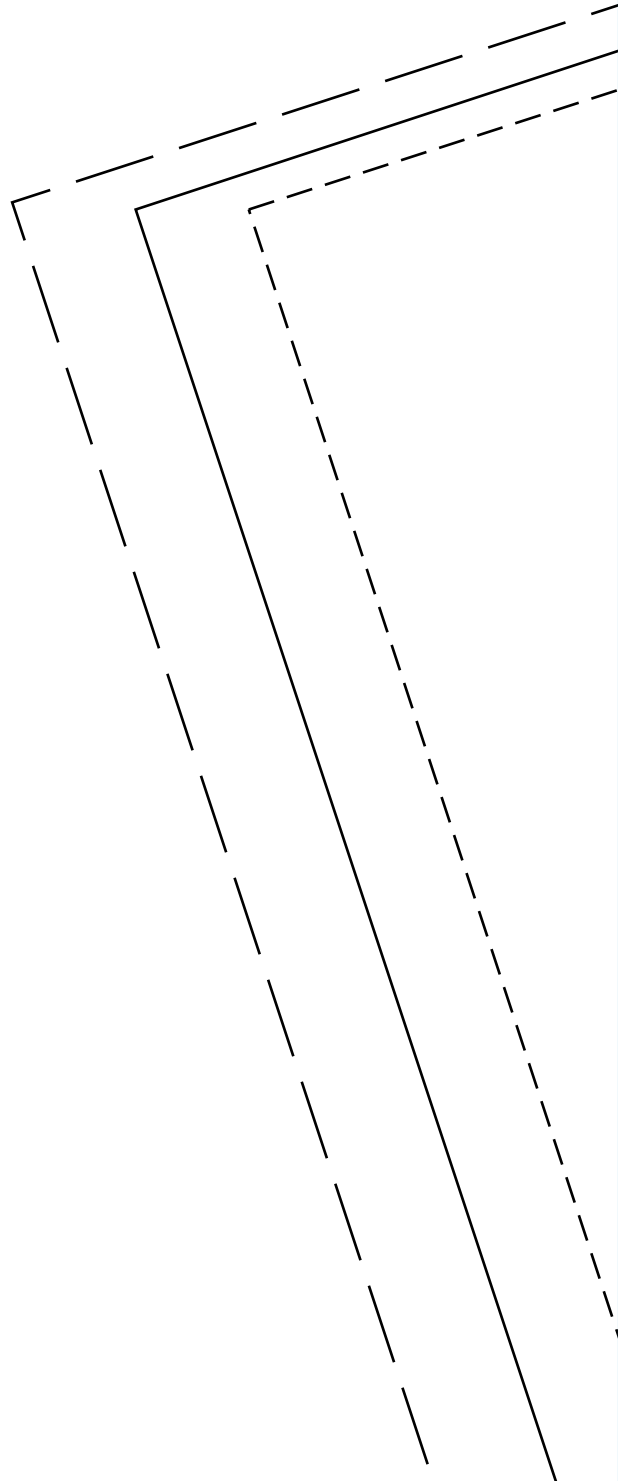

4

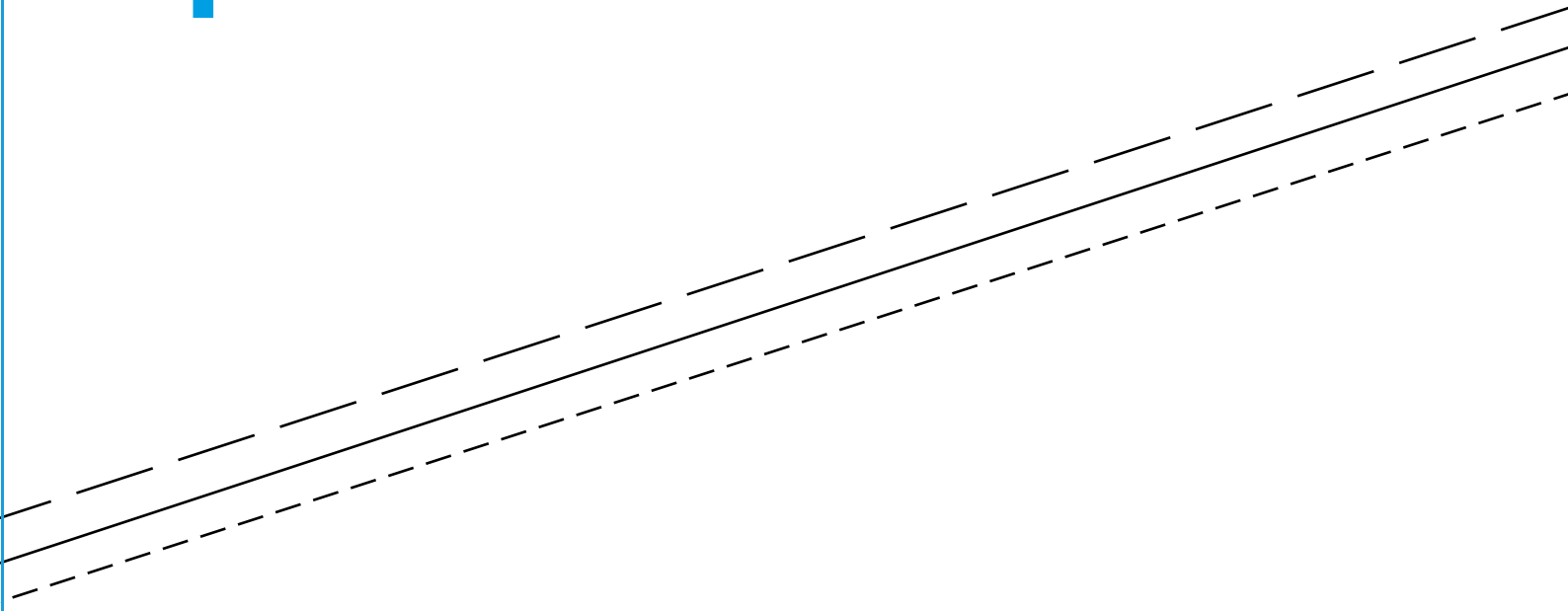

FRONT TOP

Cut one on fold

5

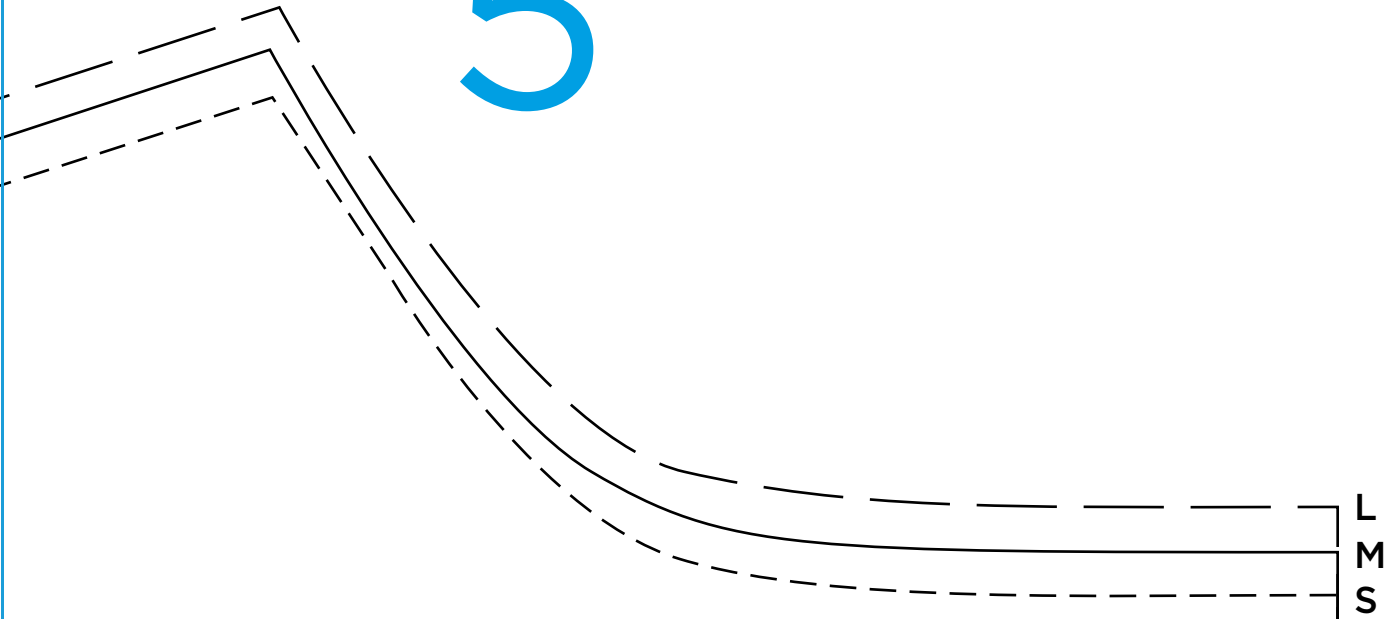

L
M
S

6

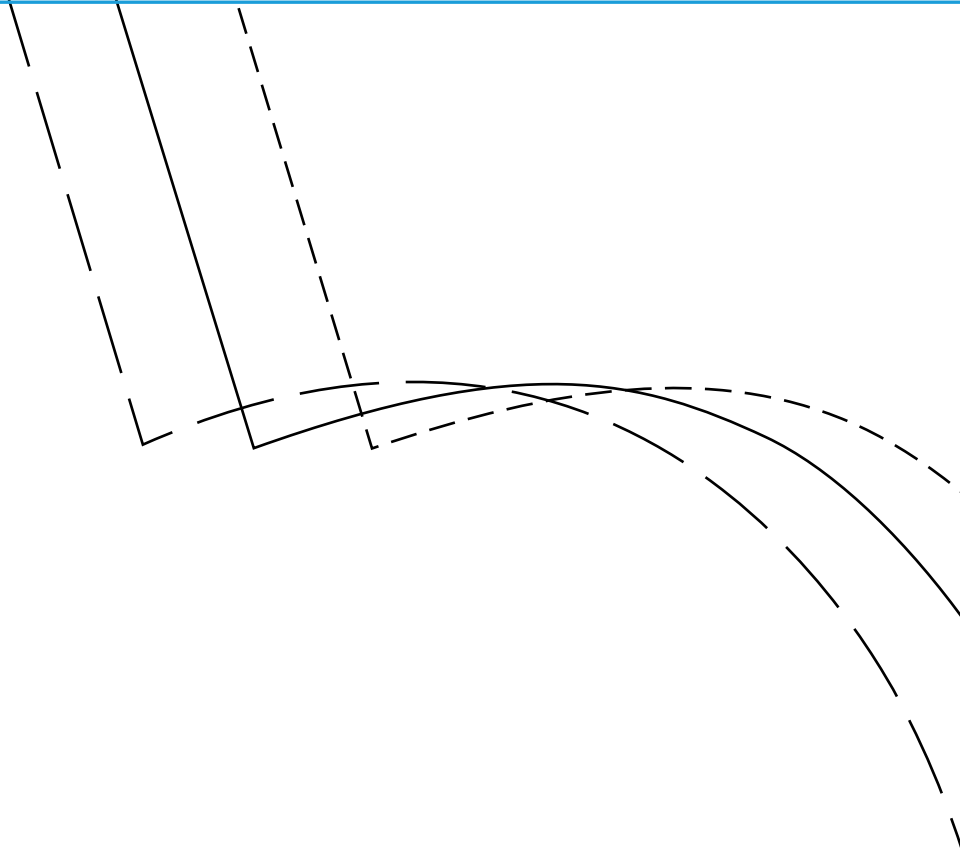

7

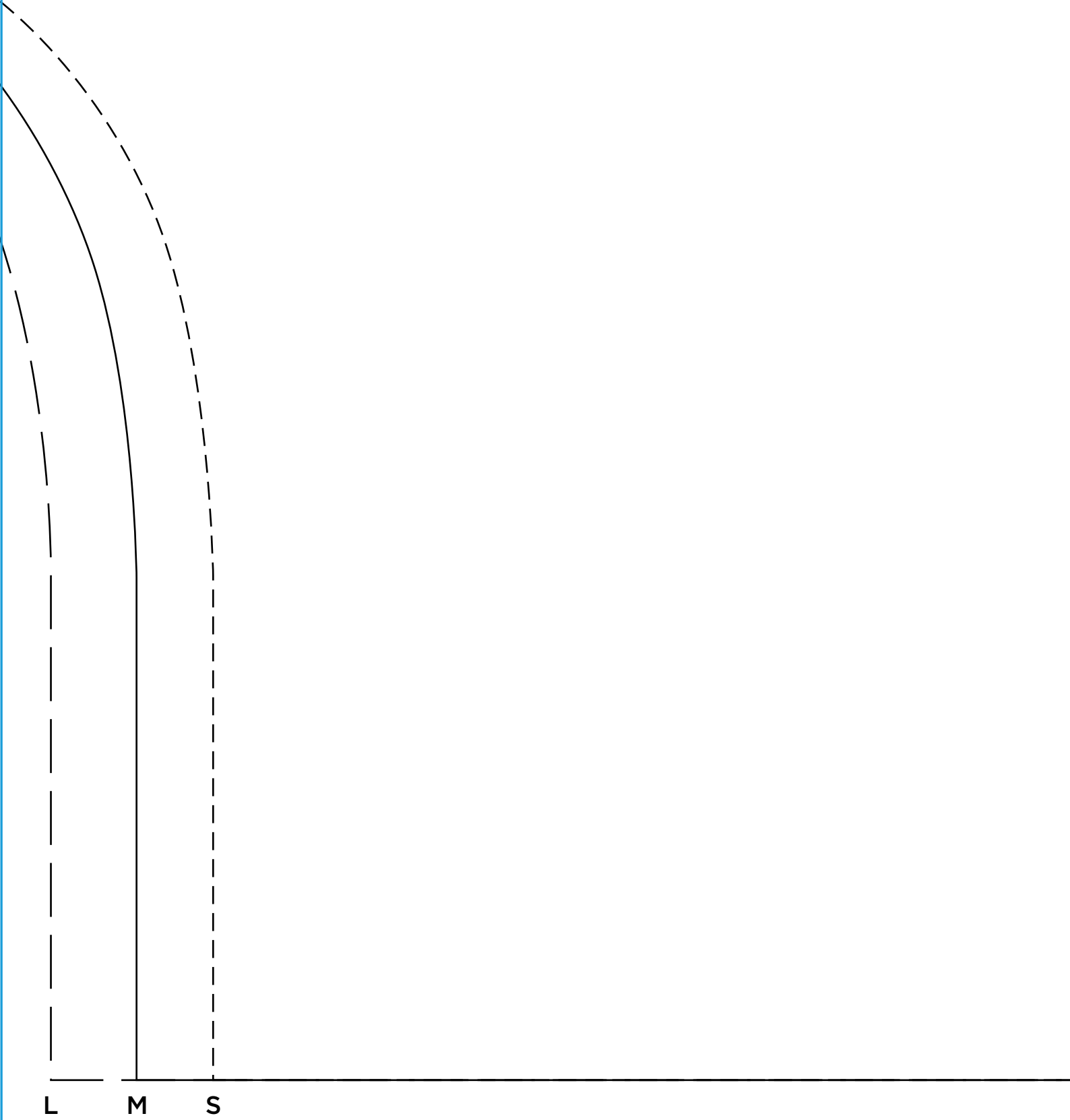

8

Place on fold

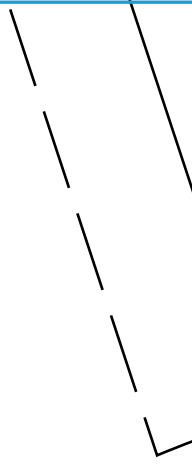

9

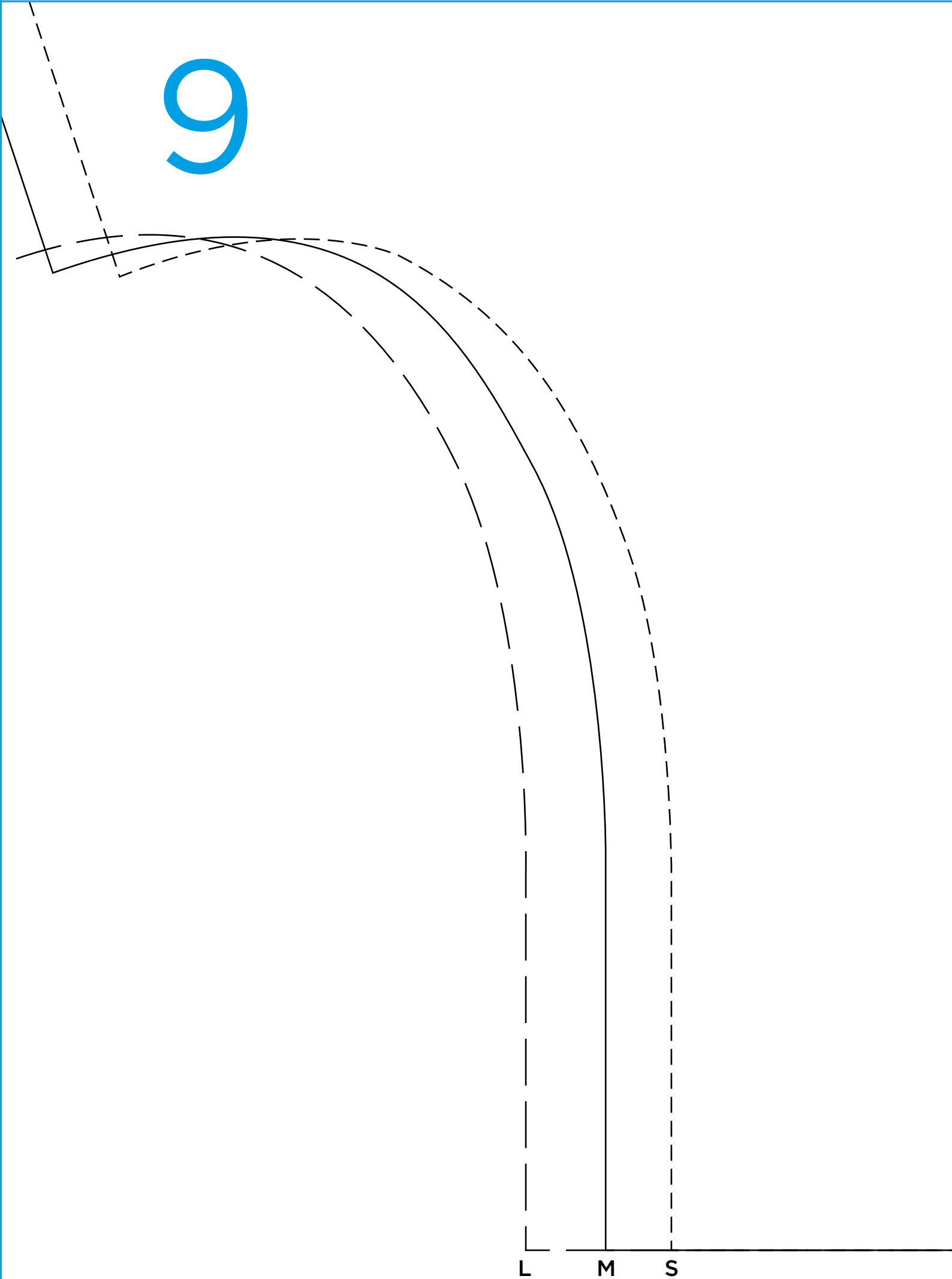

L

M

S

10

Place on fold



Page 13-17

Title: Fur stole

Designer: Amanda Walker

Magazine page: 40

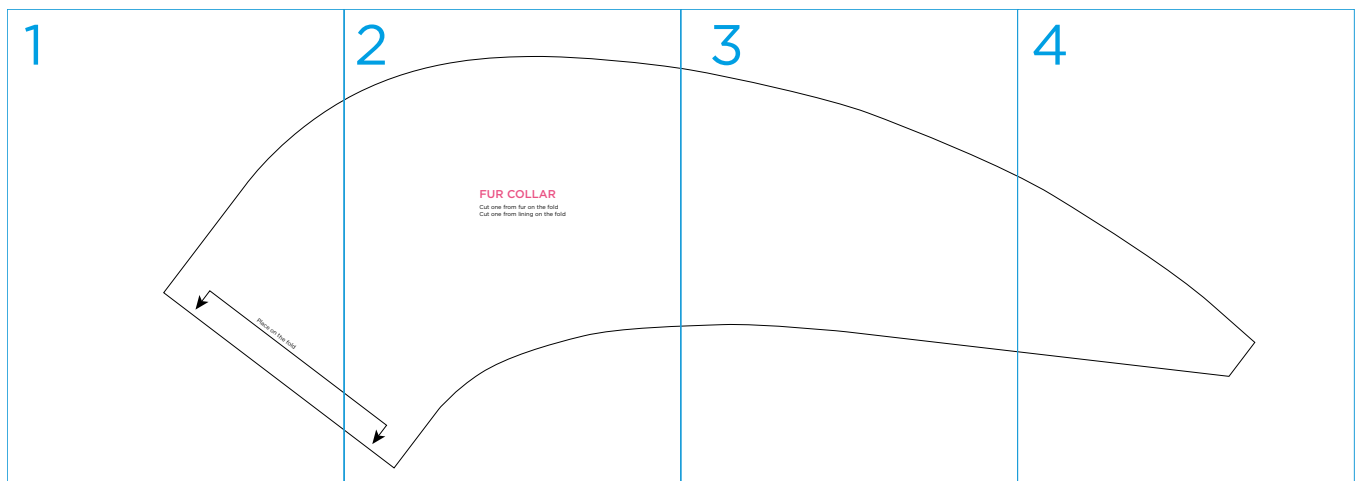

1

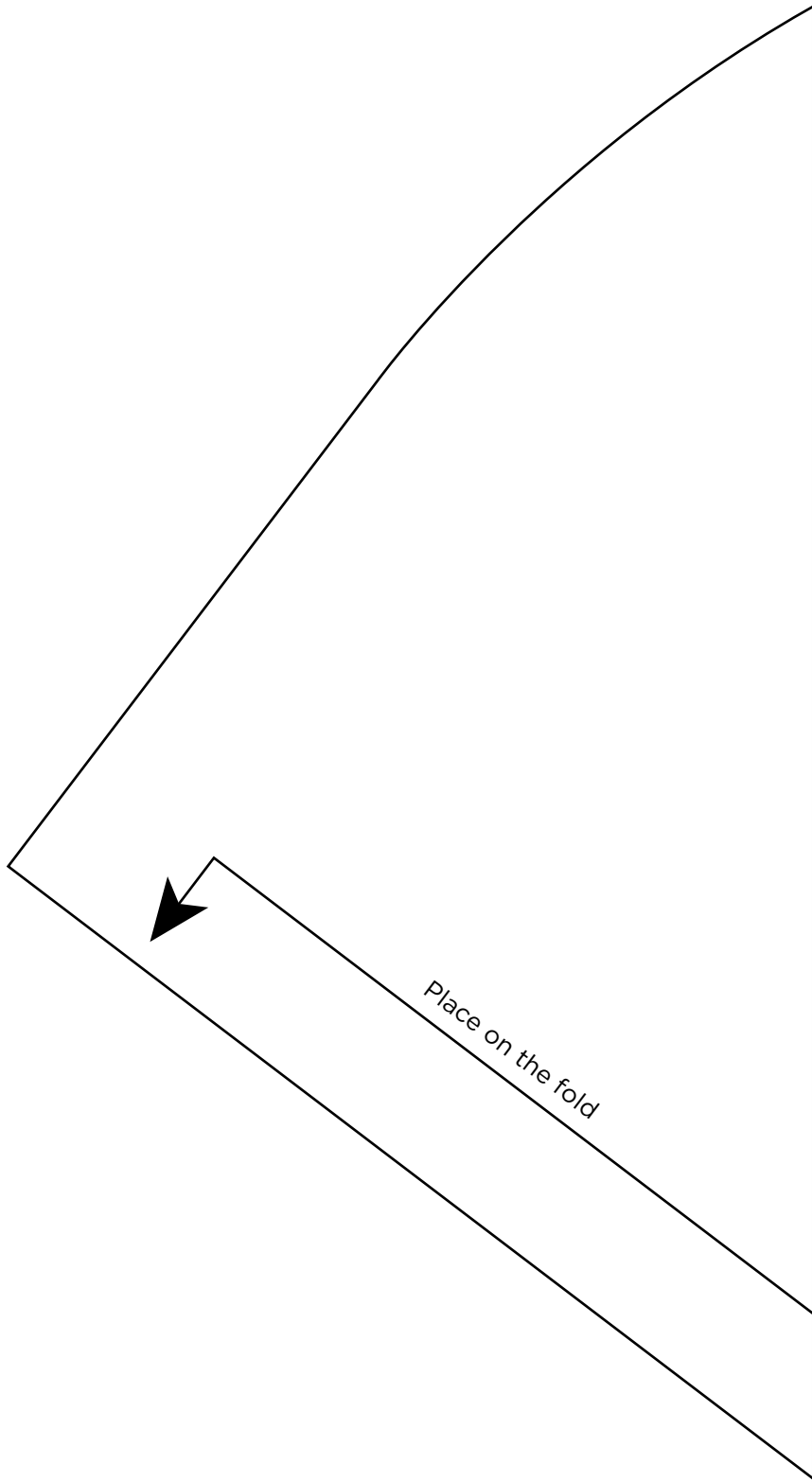

2

FUR COLLAR

Cut one from fur on the fold
Cut one from lining on the fold

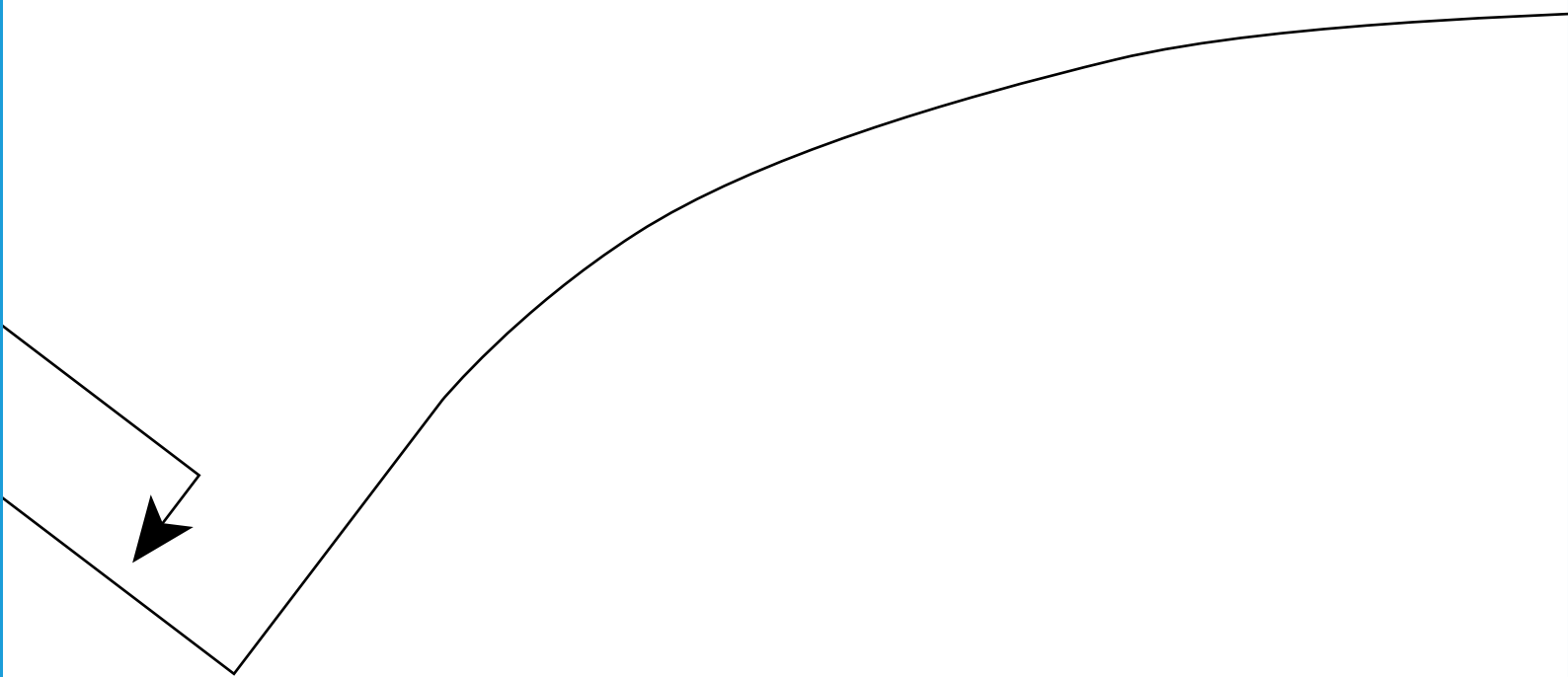

3

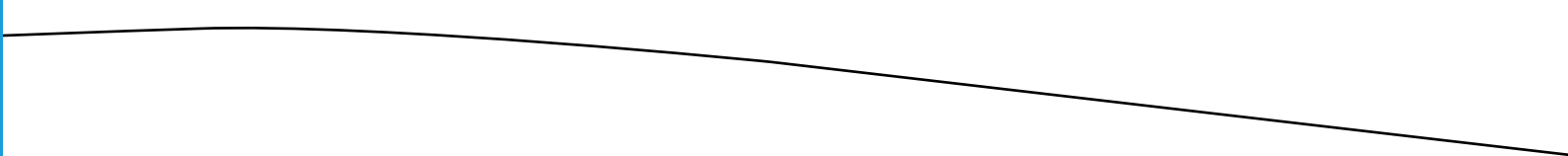
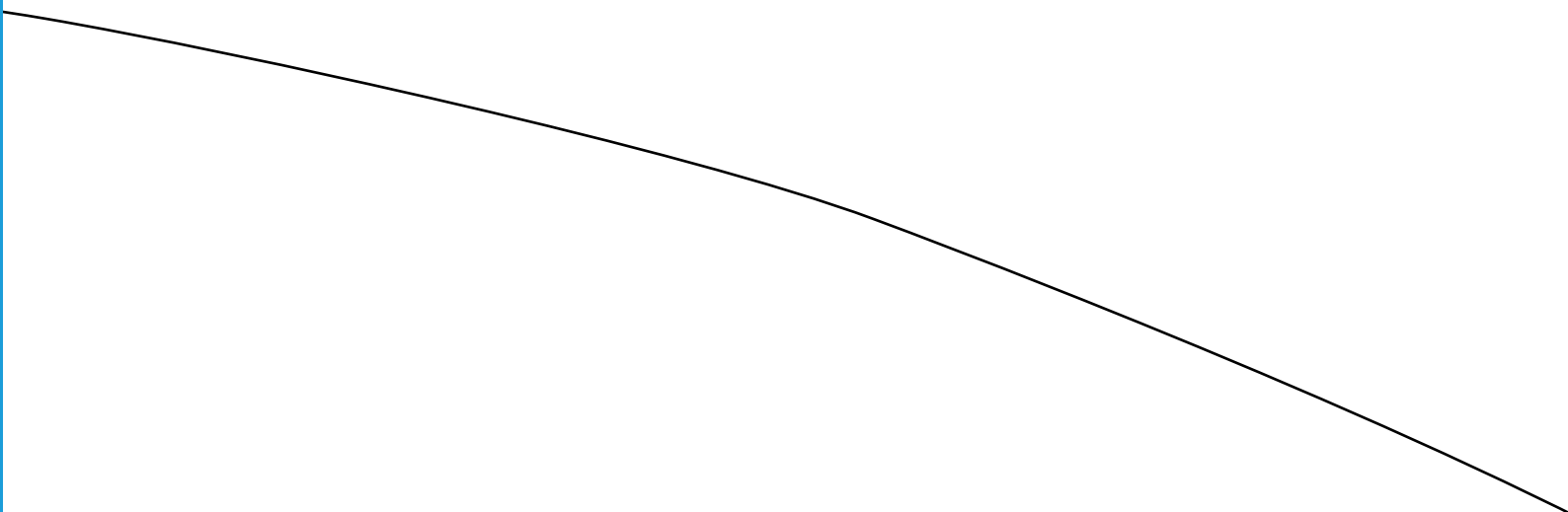

4

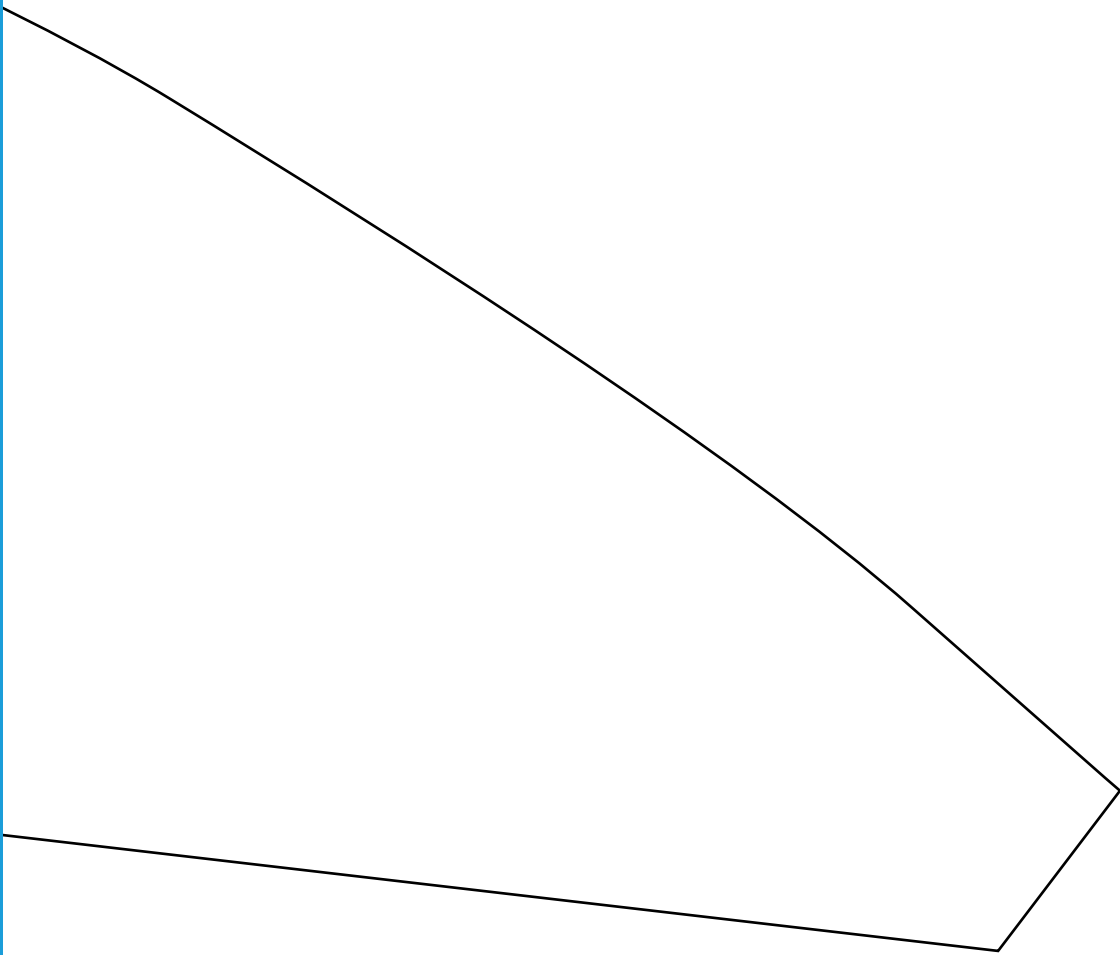

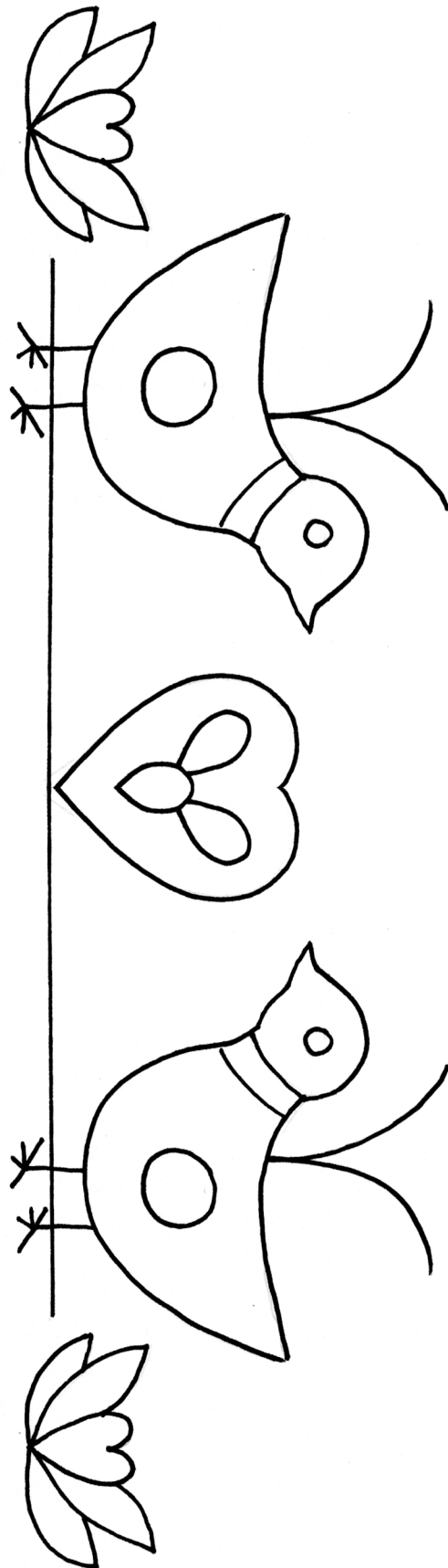

Title: Reindeer runner

Designer: Kelly Fletcher

Magazine page: 68

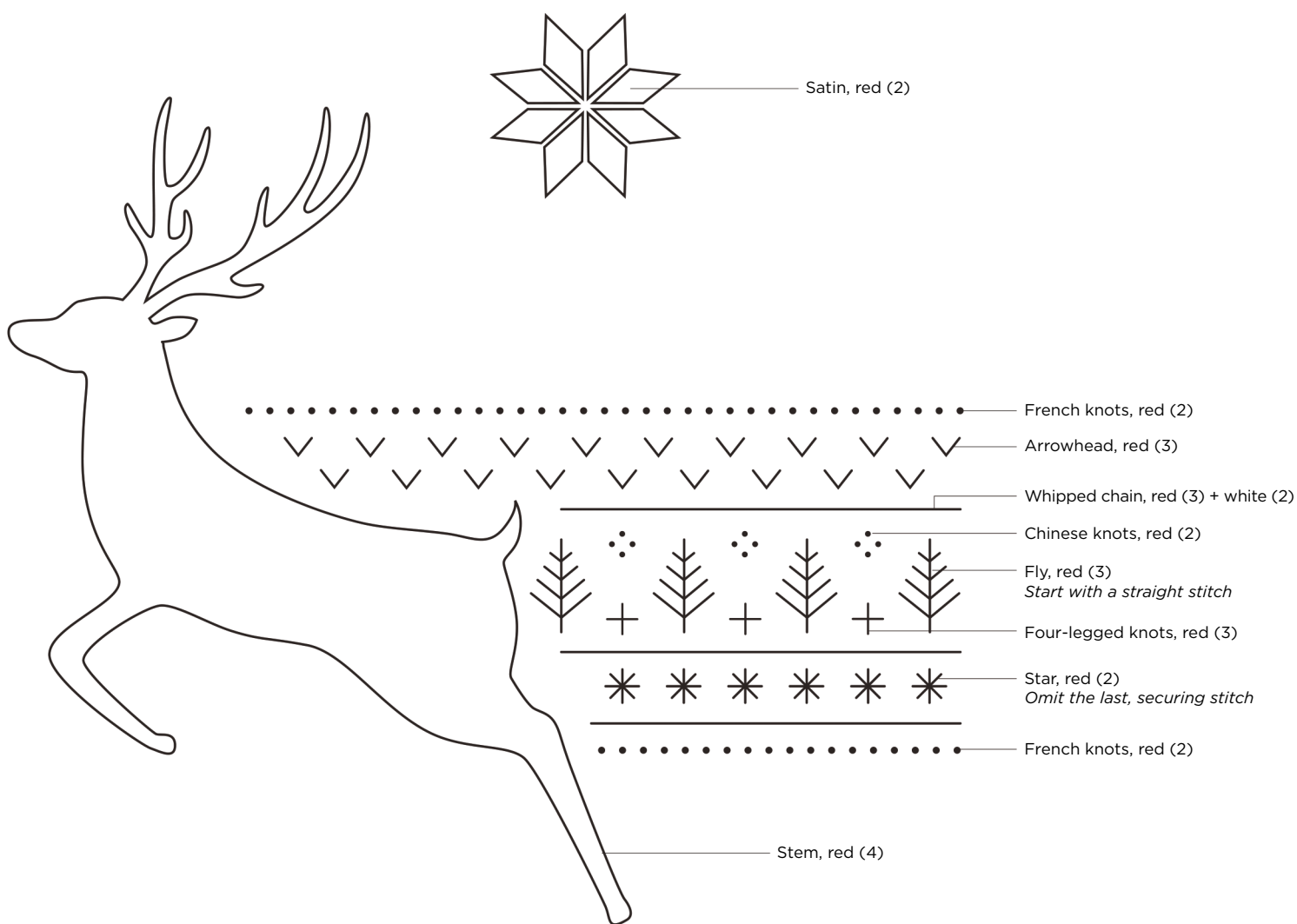

1

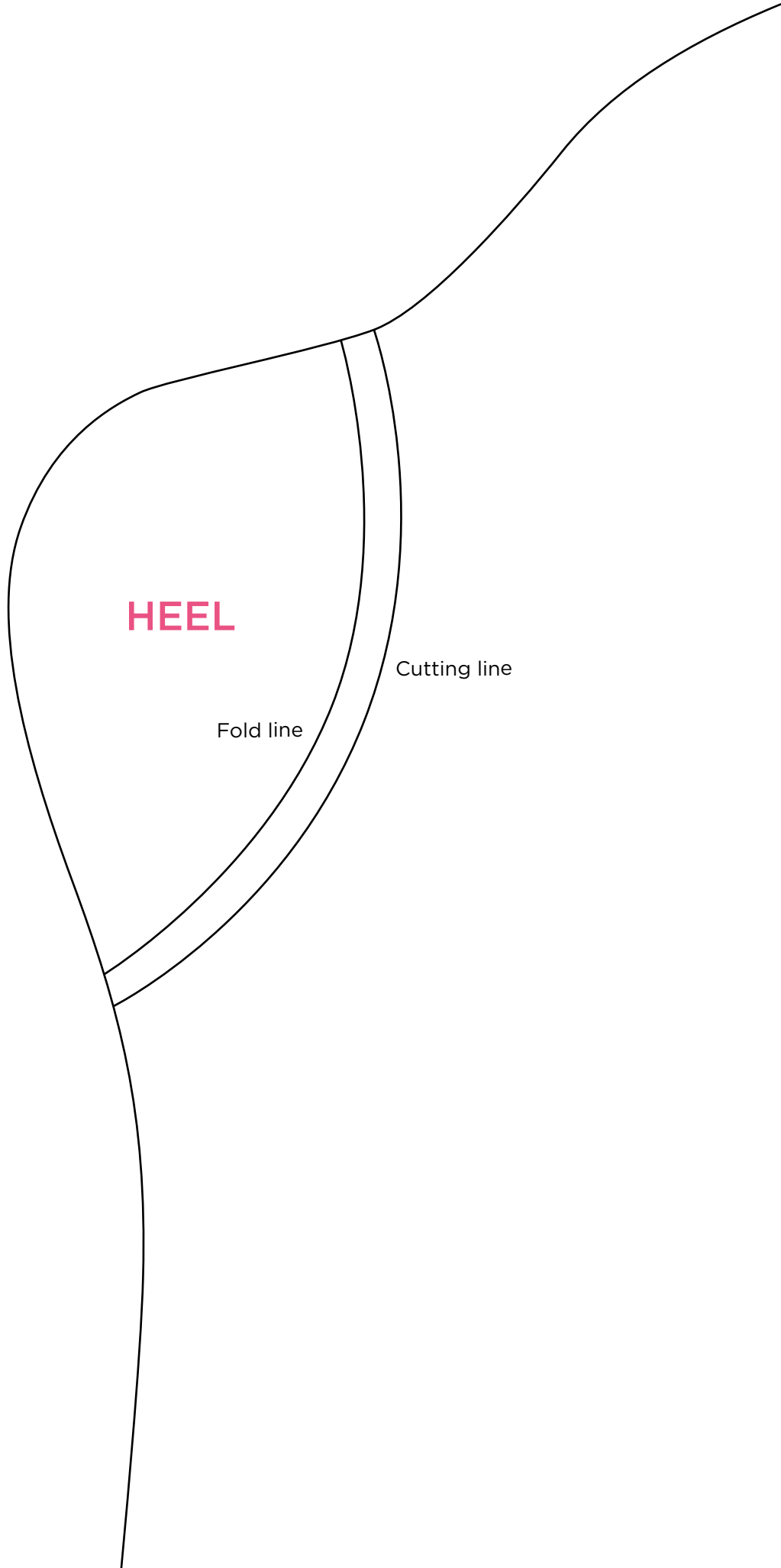

2

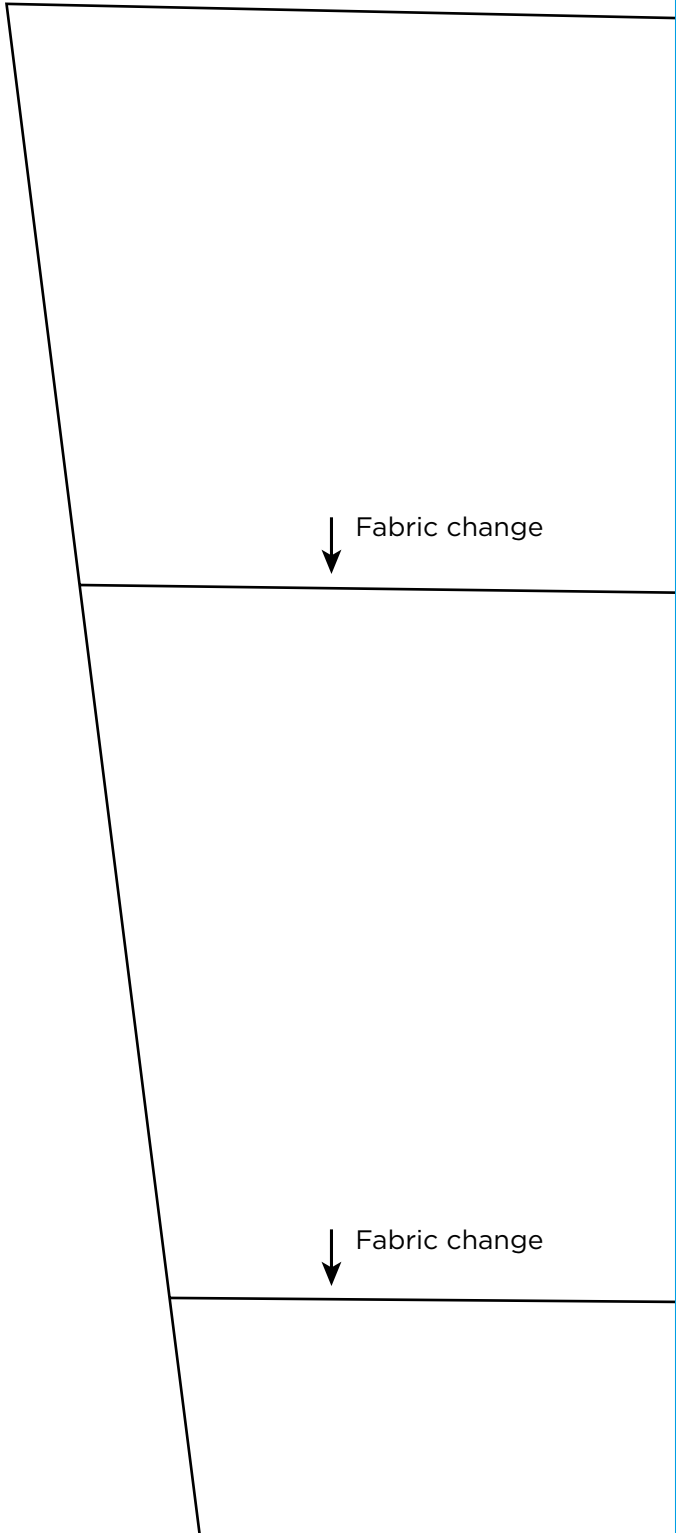
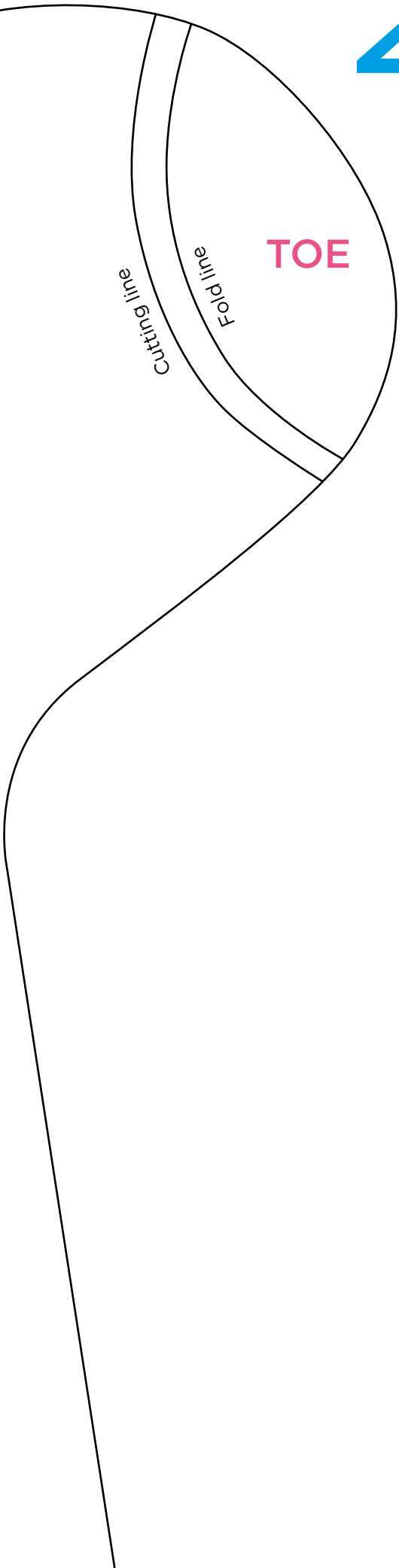

Merry Christmas

3

4

SMALL STOCKING

SMALL STOCKING TOP

5

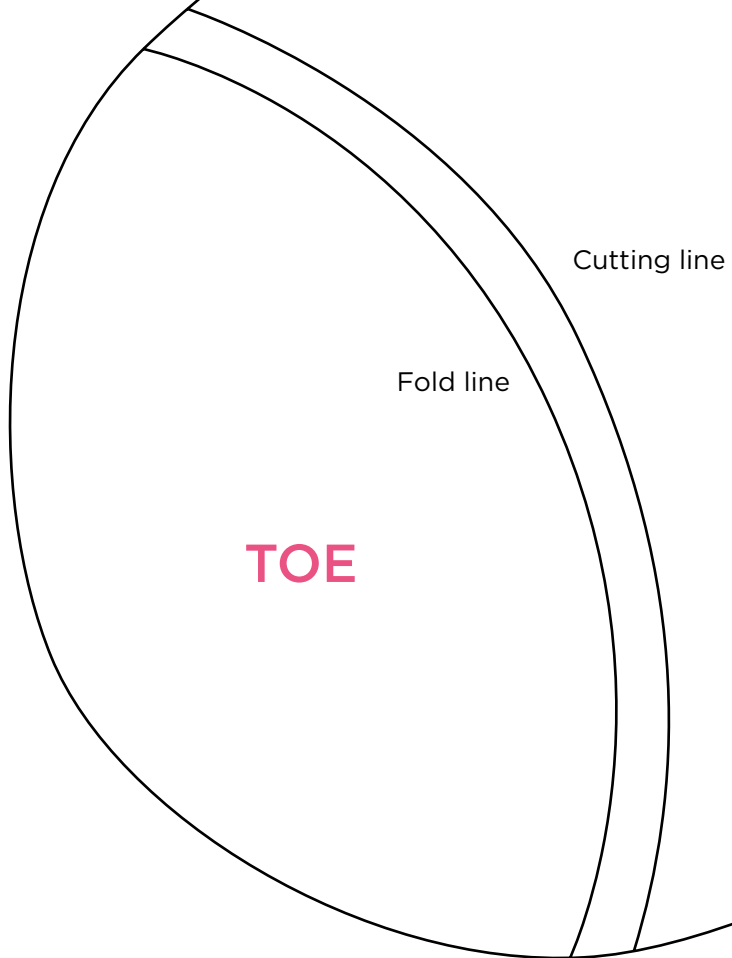

6

**REVERSIBLE
STOCKING**

Cutting line

Fold line

HEEL

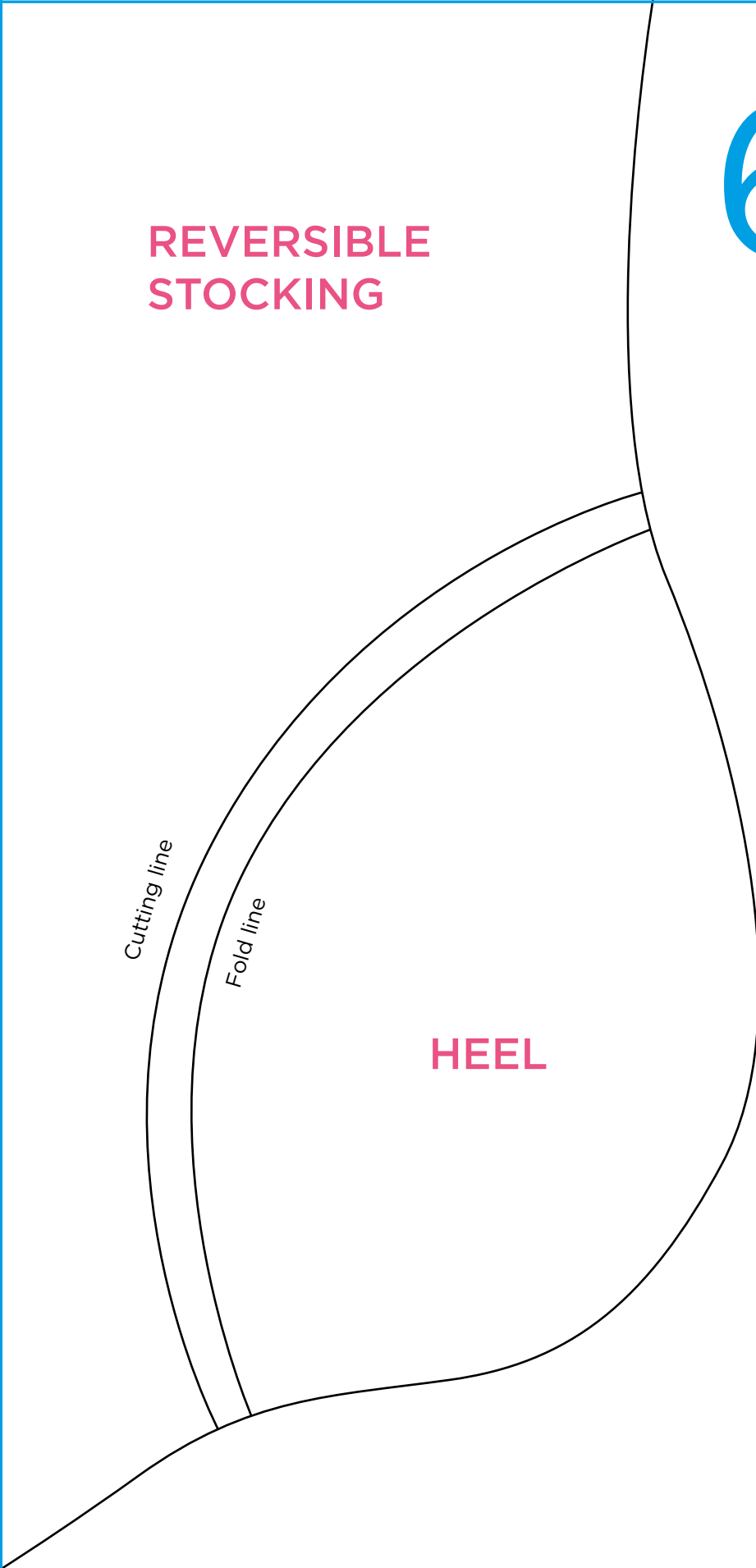

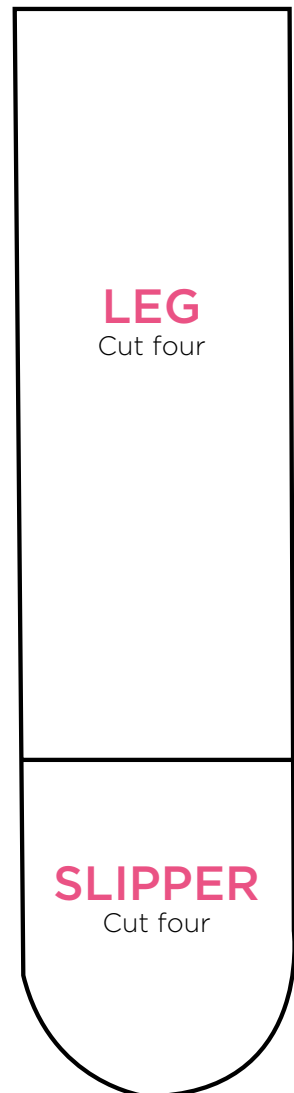
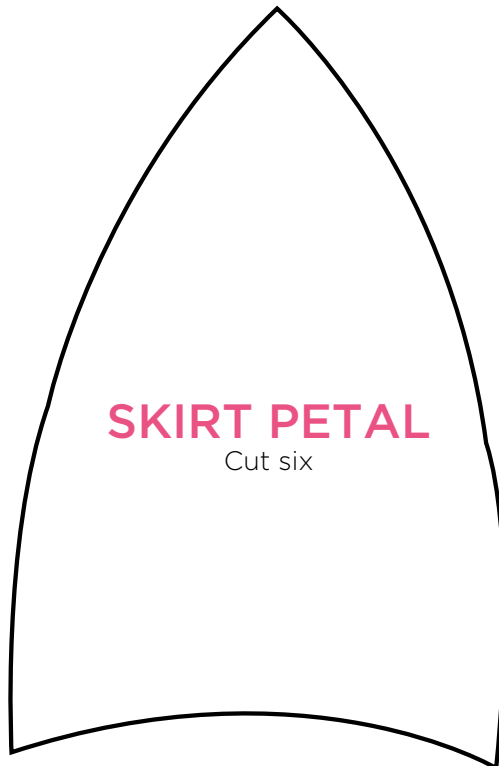
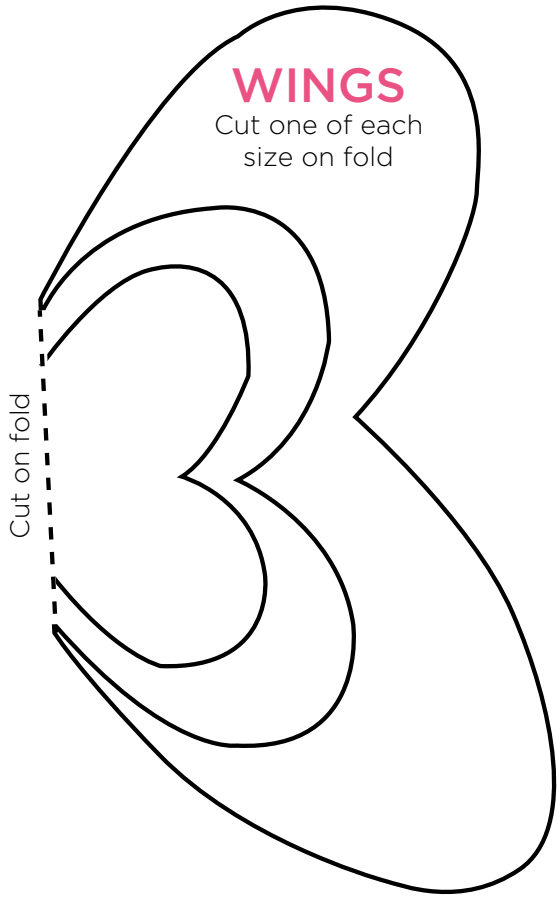

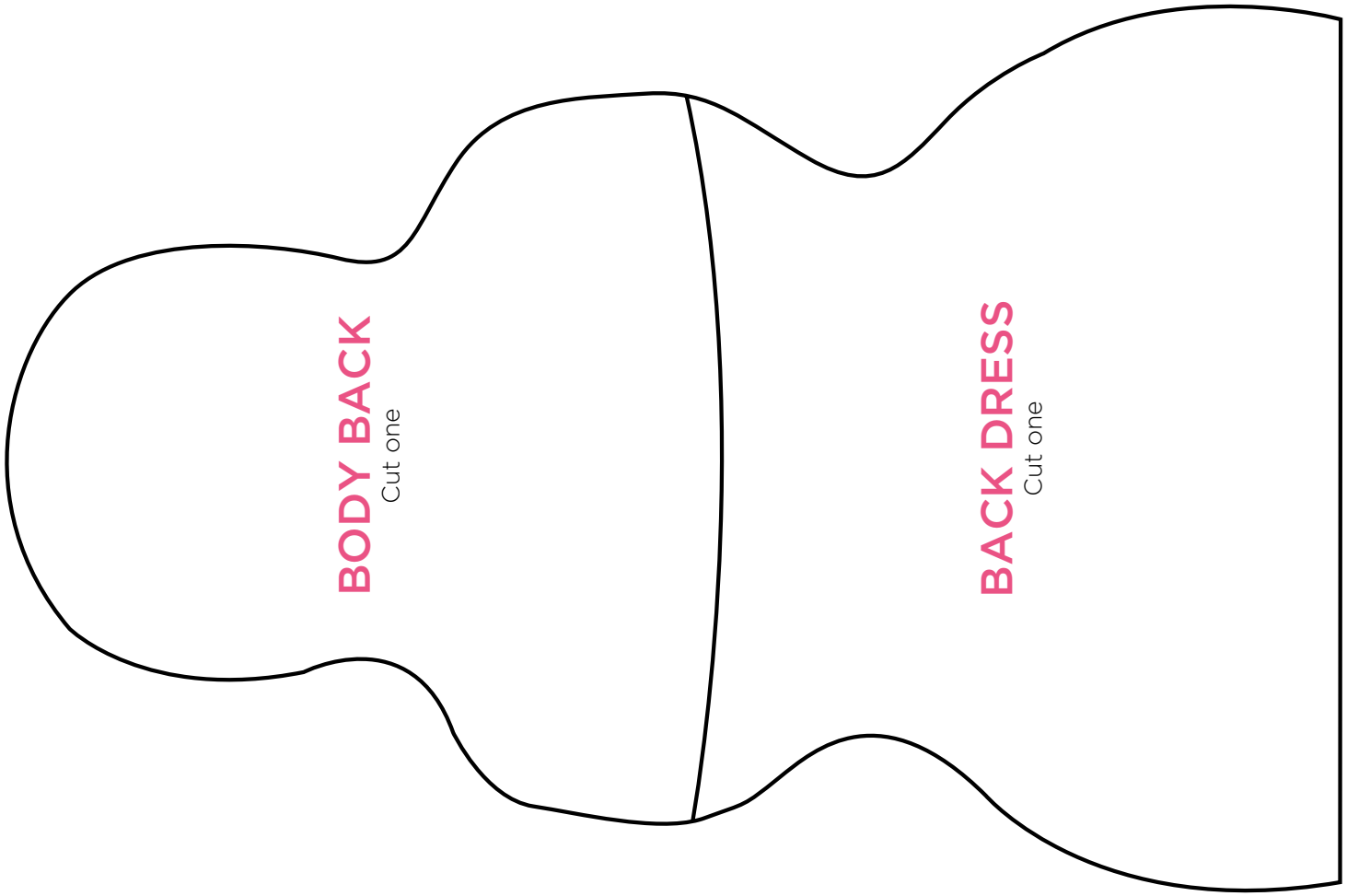
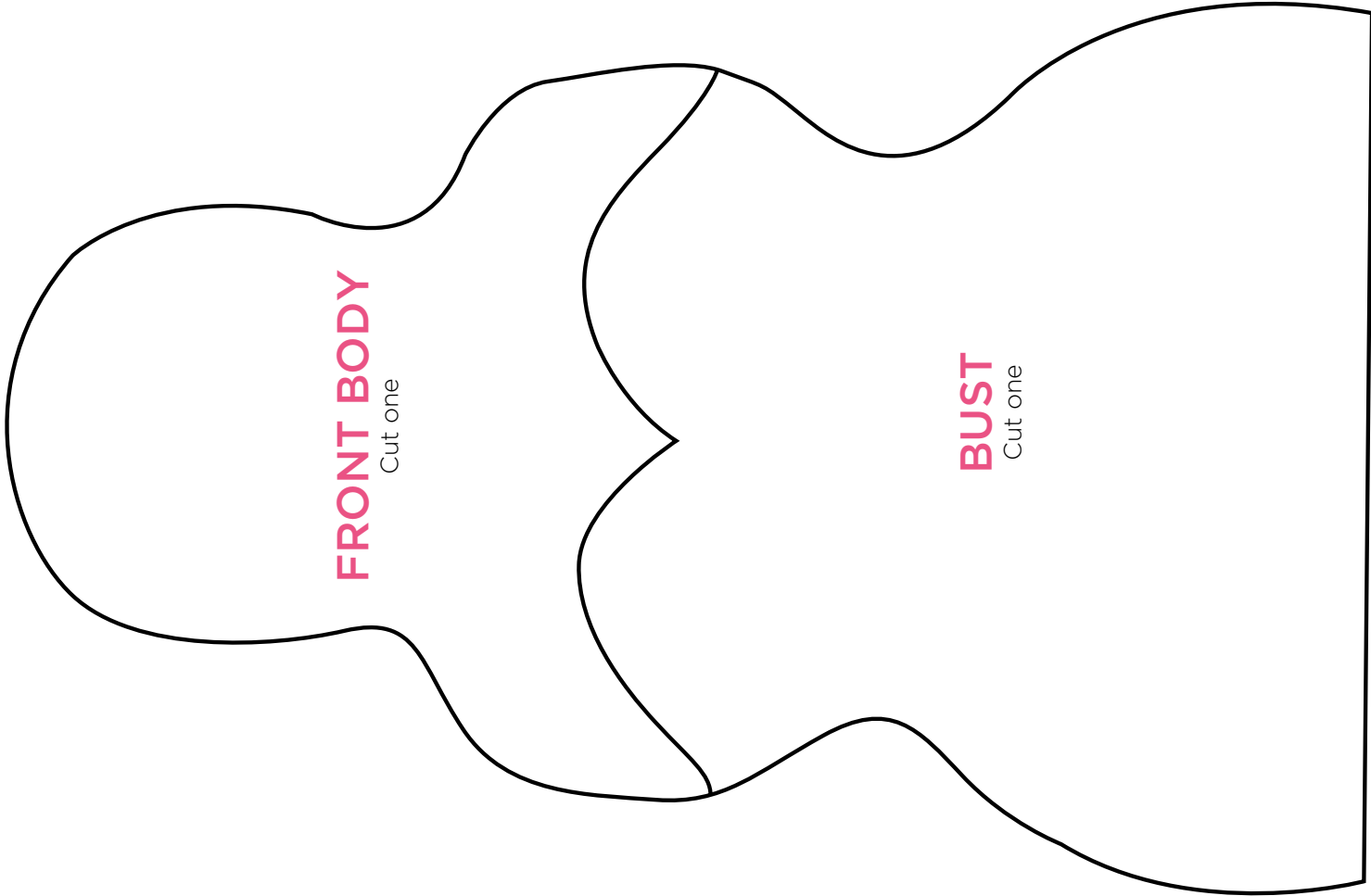

LAYOUT DIAGRAM

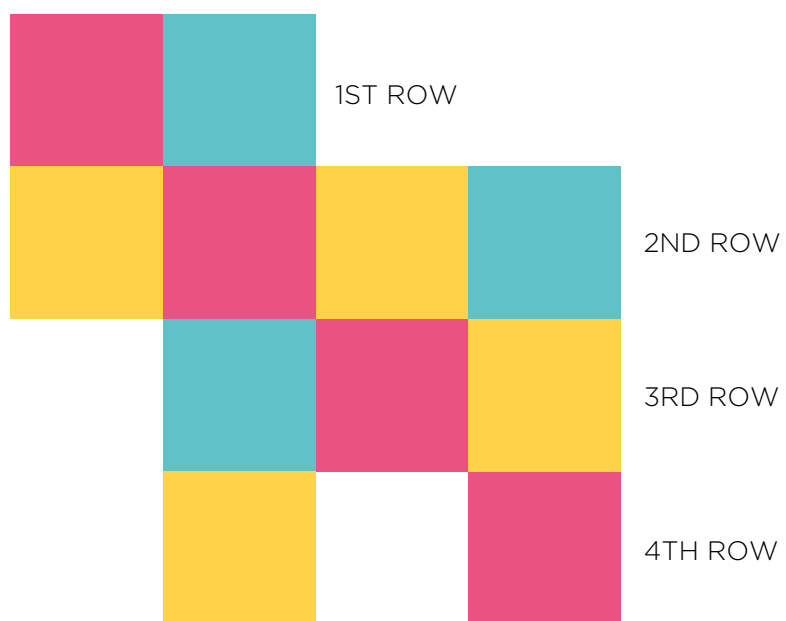

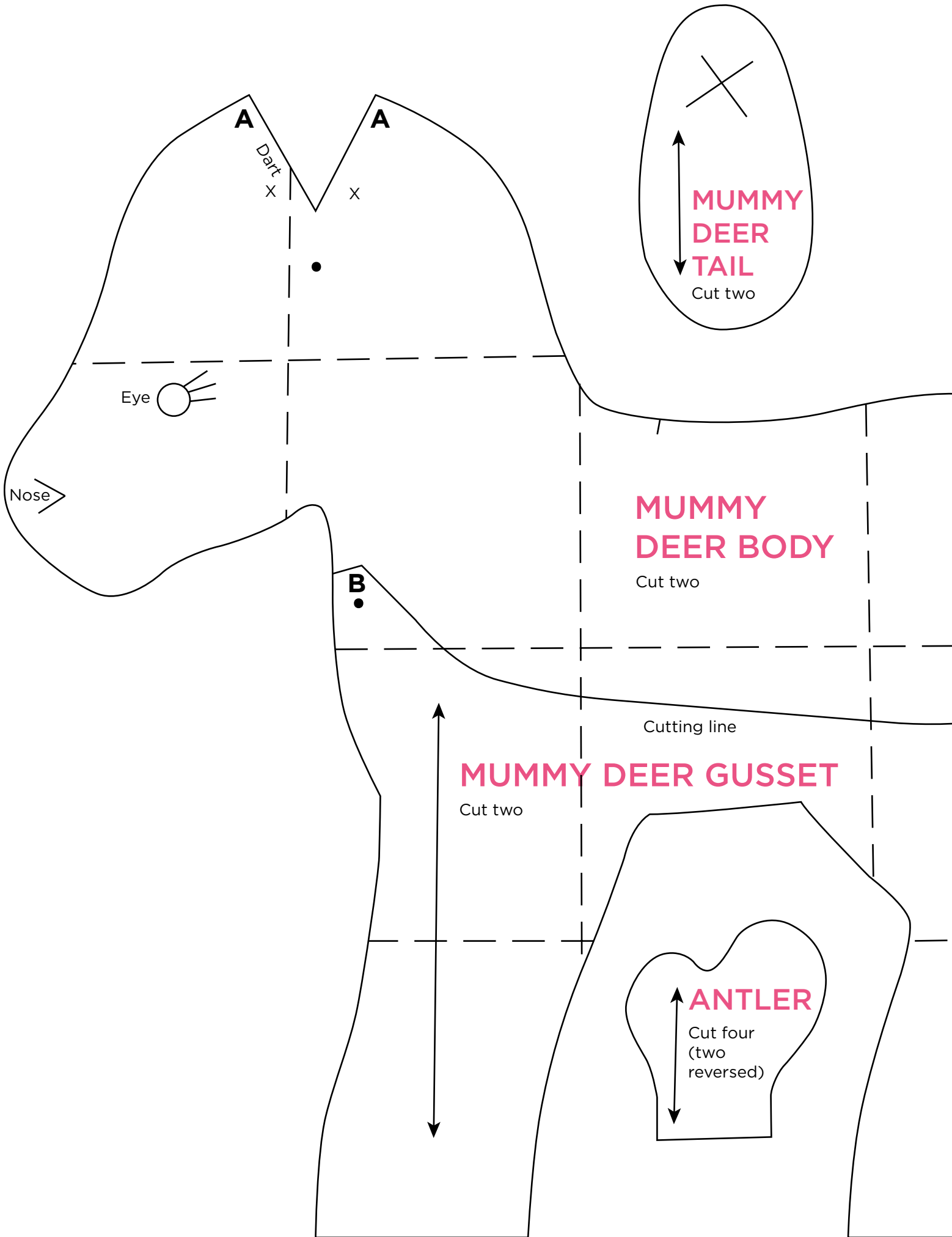

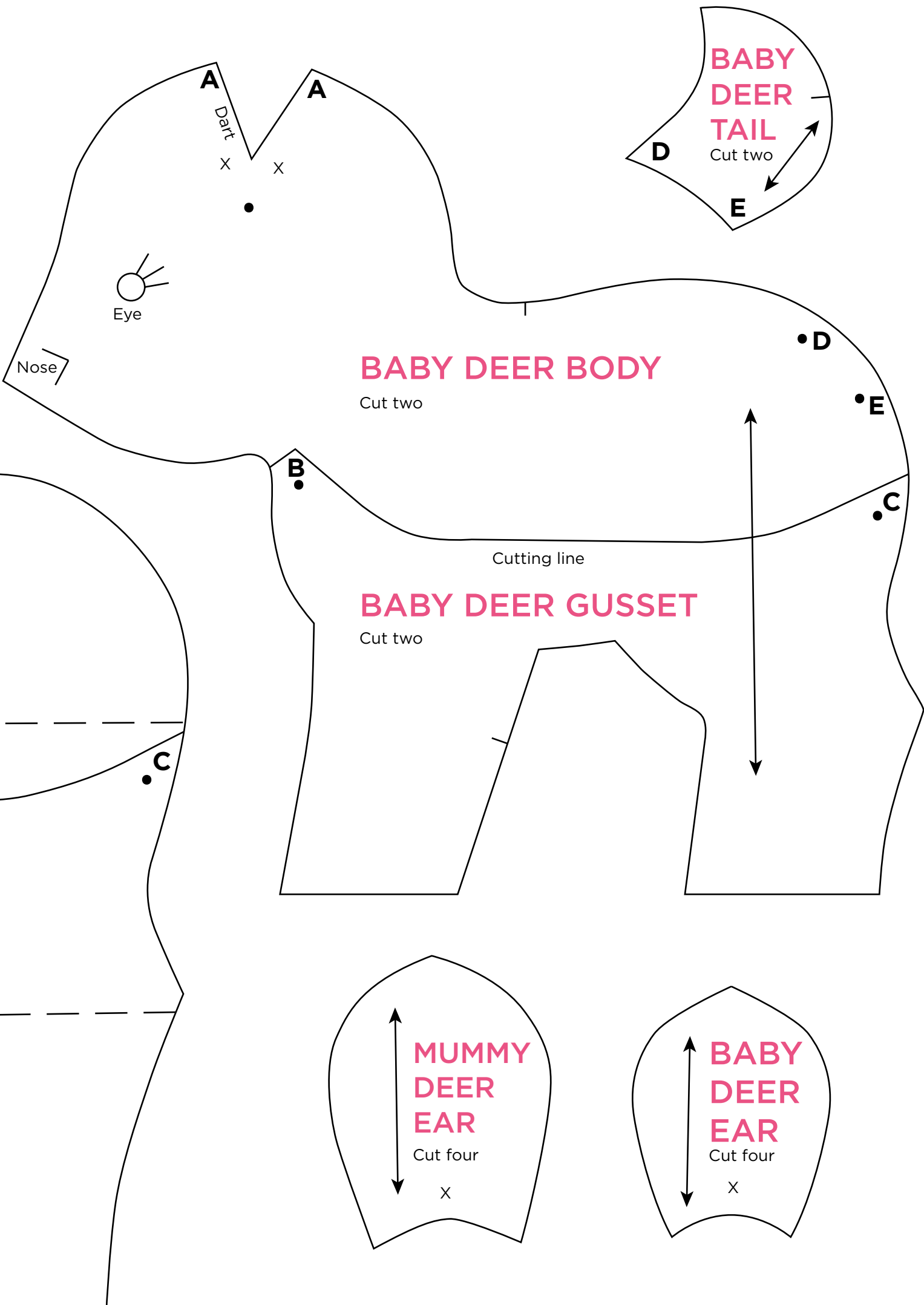

BABY DEER TAIL

Cut two

BABY DEER BODY

Cut two

BABY DEER GUSSET

Cut two

MUMMY DEER EAR

Cut four

BABY DEER EAR

Cut four

A
Dart
x

A

Eye

Nose

Cutting line

C

B

D

E

C

x

x

Title: Debbie Shore shows you how

Designer: Debbie Shore

Magazine page: 98

1

2

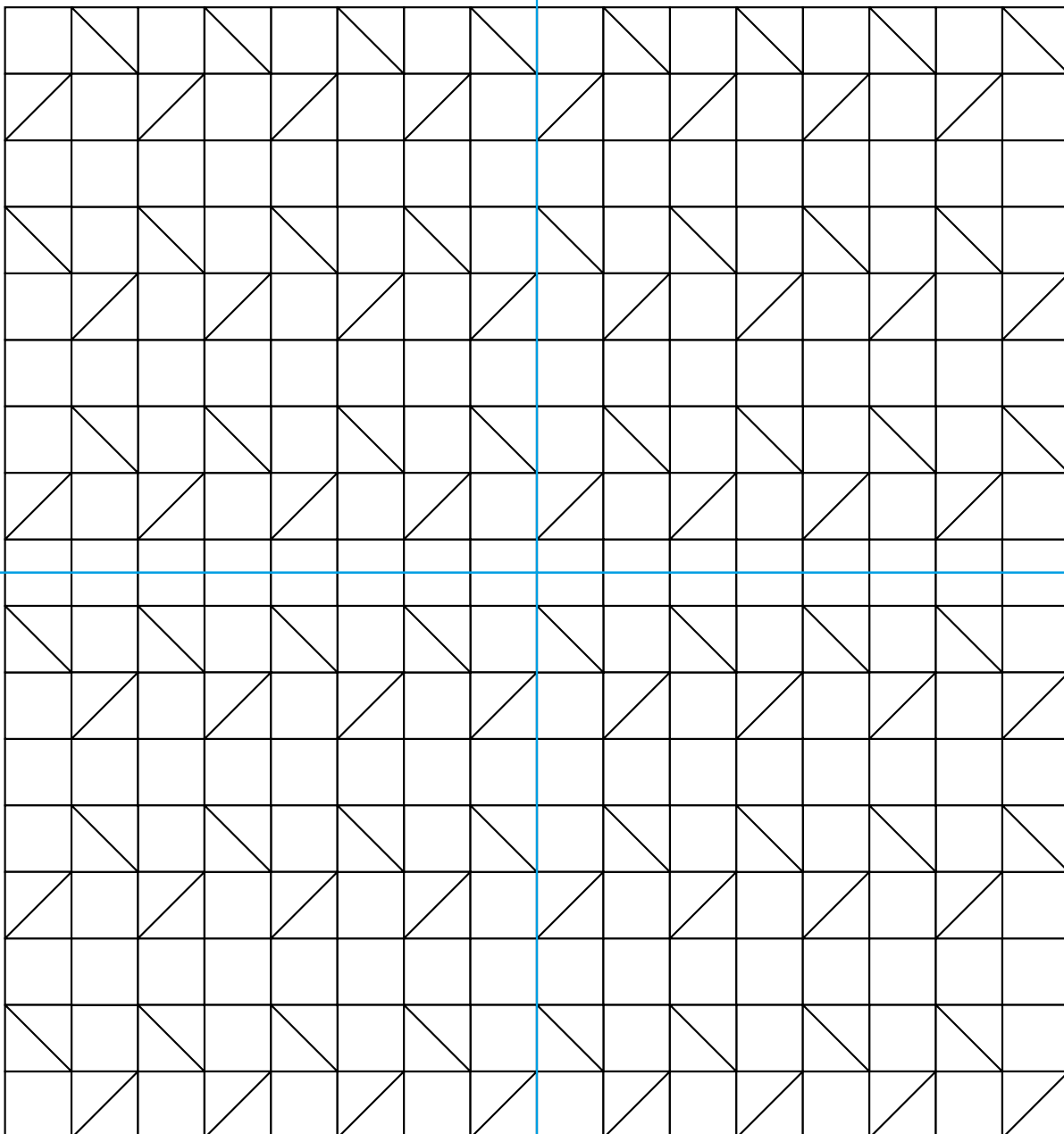

Top left

3

4

1

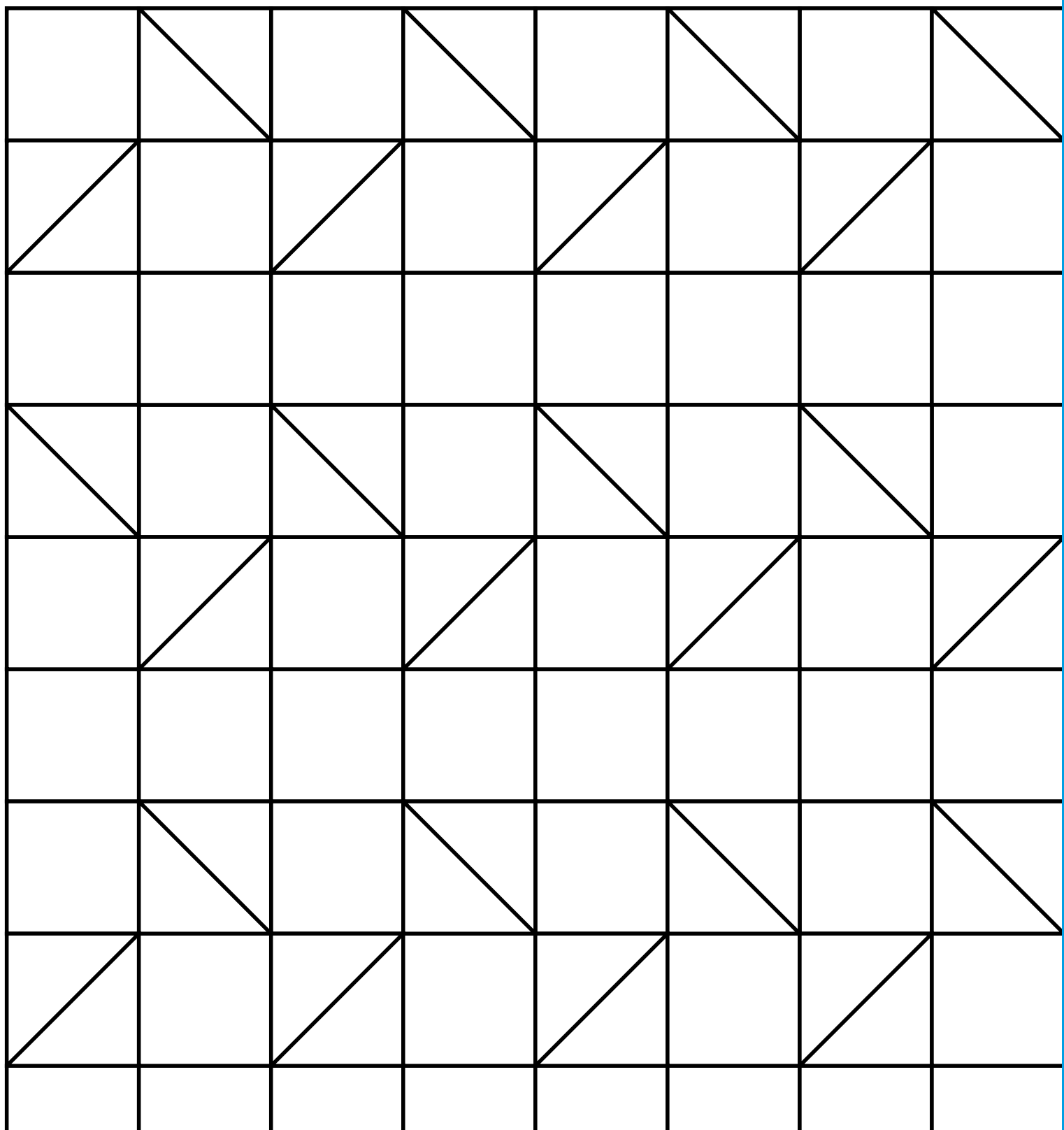

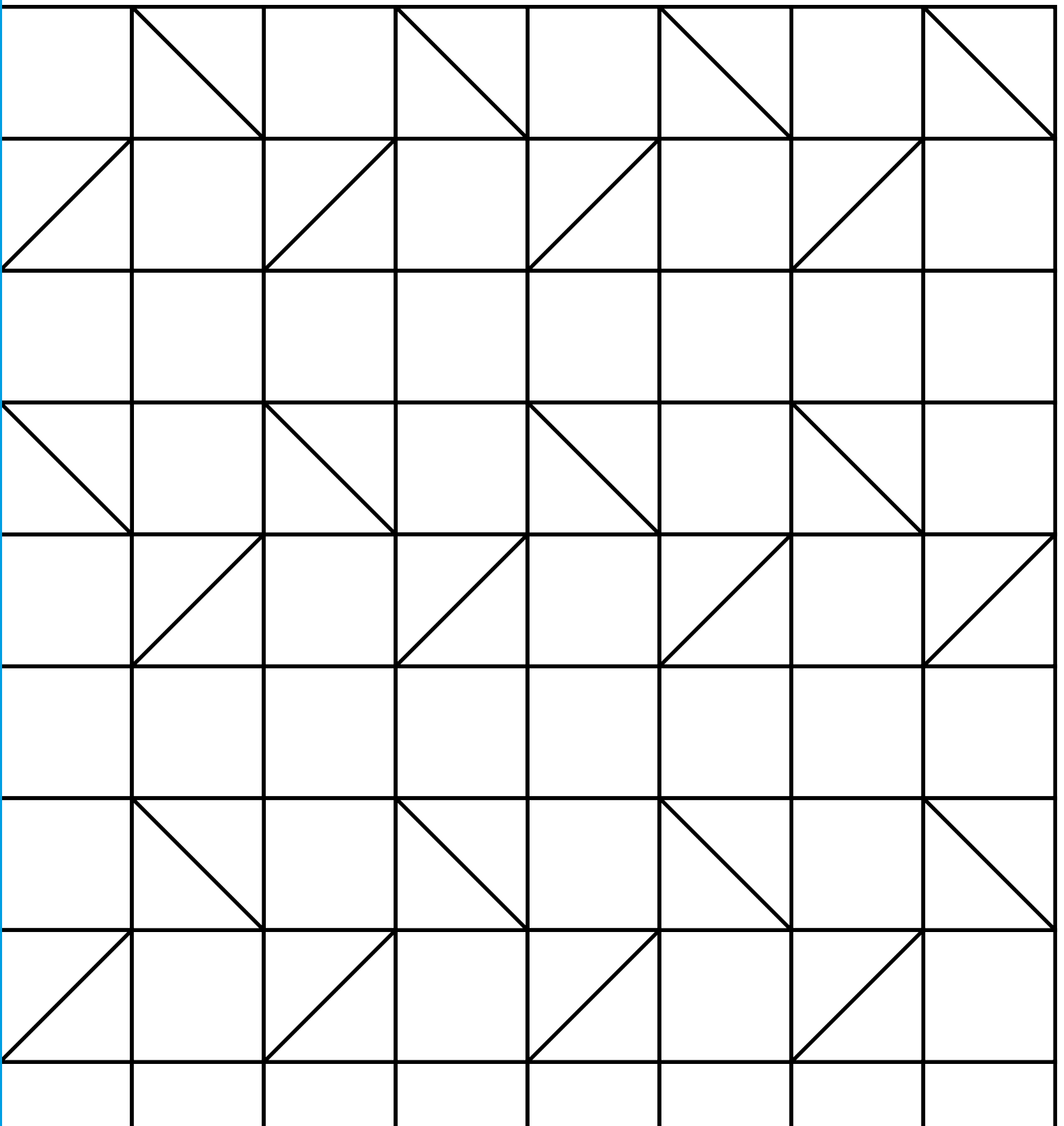

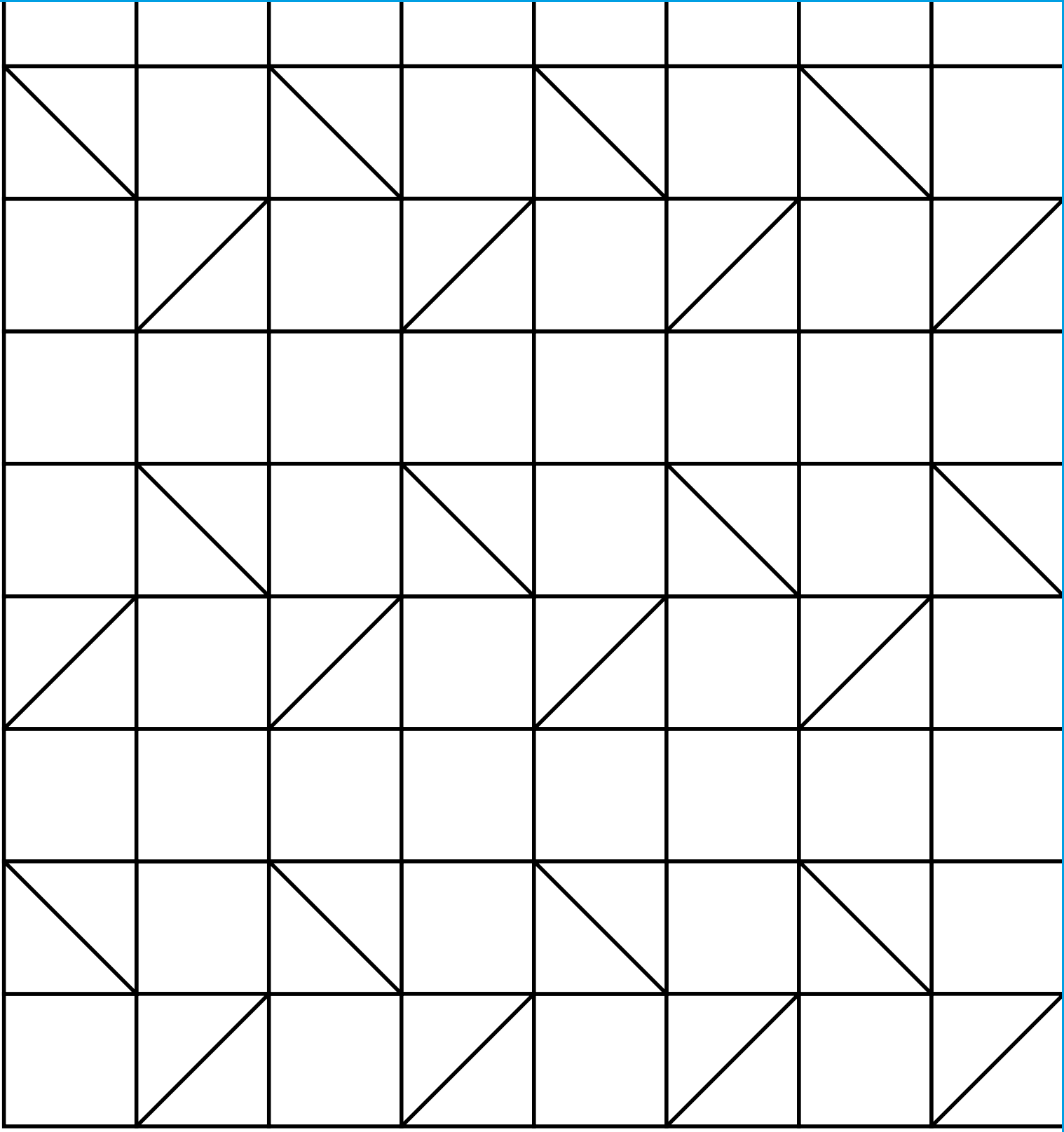

Top left

3

